

Angle brackets

heavy-duty version, hot-dip galvanised

Application

- Installation of pipelines on the wall and ceiling
- For the assembly of fittings and devices
- For indoor and outdoor use

Your advantages

- Particularly stable version for heavy pipelines and aggregates
- Oblong holes for a flexible positioning of the loads
- Variety of lengths covers all construction requirements
- Round holes in the side of the U-profile for additional braces, e.g. at fixed points

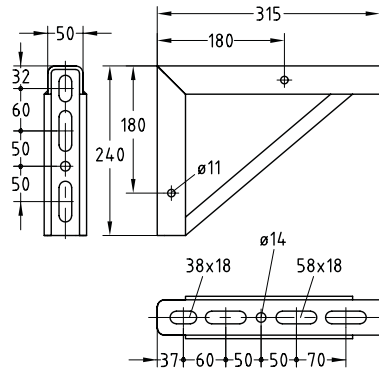

Size 1

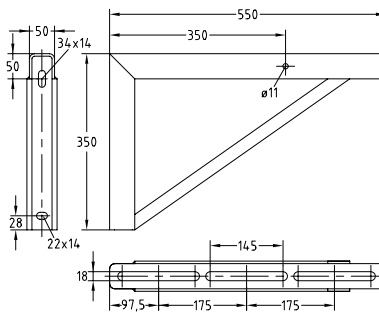

Size 2

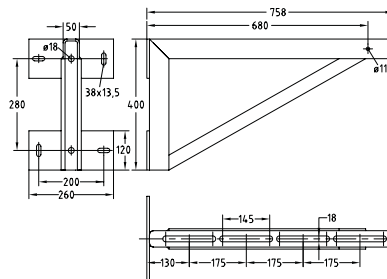

Size 3

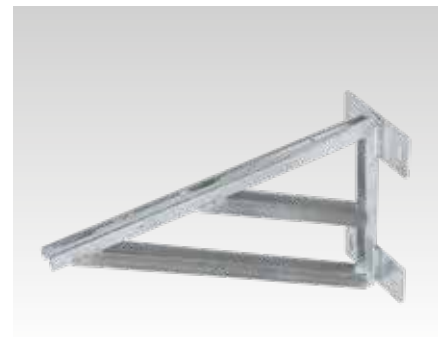
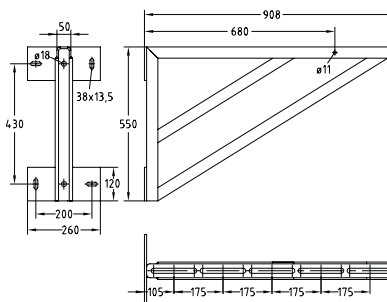

Size 4

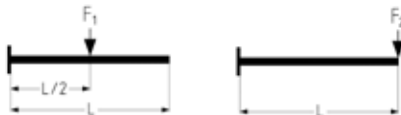

Features

Size	Length [mm]	Permissible load F ₁ [N]	Permissible load F ₂ [N]
1	315	4,900	6,000
2	550	6,000	7,000
3	750	7,200	8,000
4	900	6,800	7,200

Size	Length [mm]	Part no.	Sales unit	Pack unit
1	315	175242	1	Pieces
2	550	175243		
3	750	175244		
4	900	175245		