

### PHONOLYT®

galvanised

#### Application

- The ideal component for vibration controlled anchor points for pipes to meet the vibration control requirements of DIN 4109 and VDI 4100
- Versatile use, e.g. for vibration control of support structures made from MPC-Support channels
- Ideal as vibration decoupled down pipe-support for all pipe types
- Ideal for vibration controlled fixing of devices such as boilers, pumps, motors, air-conditioning and ventilation systems
- Suitable for ceiling, wall or floor mounting
- For sound-decoupled pipeline fixed points

#### Your advantages

- Vibration decoupler available in two versions for different duties
- Isolates the pipe acoustically from the building structure
- Reduces the structure-borne noise by up to 40 dB(A)
- Predictable vibration control for planners and users
- Practical design made for easy installation
- High static loading capacity
- Encapsulated vibration control - safety that you can rely on
- Effective isolation of vibration coupling using vulcanised-in MÜPROLAN
- The cast-steel vibration-control capsule provides a high degree of safety, even in the case of fire
- Approved for all installation positions
- Silicone-free



#### Features



Type	dB(A) 27	dB(A) 40
Average vibration reduction [dB(A)]	27	40
Max. recommended tensile load $F_z$ [N]	3,000	3,700
Max. recommended compression load $F_D$ [N]	5,700	15,000
Max. recommended load axial $F_{ax}$ [N]	2,500	5,000
Max. recommended load lateral $F_Q$ [N]	2,500	3,000

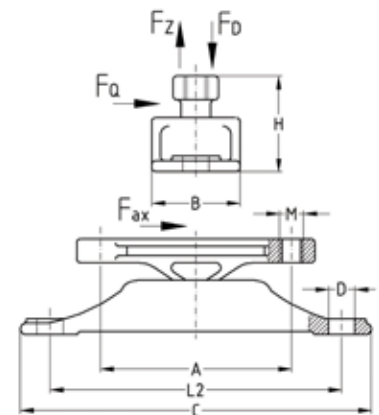

Type	Connecting thread	Dimensions [mm]						Part no.	Sales unit	Pack unit
		A	B	C	D	H	L2			
dB(A) 27	M10	80	37	147	11	40	122	120292	1	Pieces
dB(A) 40	M12	126	60	227	13	66	194	120296		