

Anchor point pipe clamps type 170 FL galvanised

Application

- Thermal decoupled pipe attachment in the field of refrigeration
- Complete anchor point pipe clamp for chilled water pipes
- For form-locking attachments taking up axial pipe forces
- For indoor use
- In particular for large nominal sizes

Your advantages

- Direct between pipe clamp and cold pipe: decreased heat flux between pipe and environment
- Low thermal transfer with the insulation shells and internal clamp bracket used
- Simplified integration in sectional pipe insulation

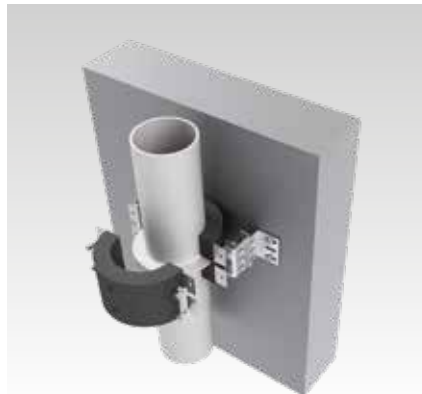

- Specially suitable for attachments of steel pipelines according to DIN EN 10022

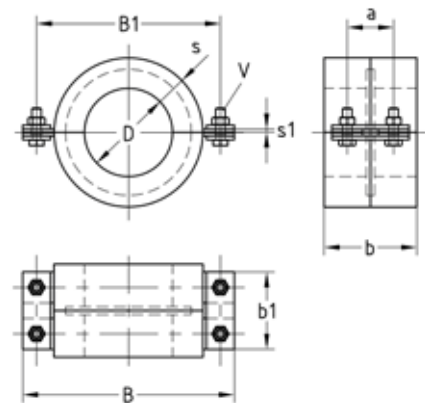

Features

Material clamp/pressure ring	S235JR
Material insulation shell	Polyurethane, black
Effective density [kg/m³]	250
Thermal conductivity	$\lambda = 0.045 \text{ W/mK}$
Fire classification	B2 acc. to DIN 4102 (normally flammable)
Temperature range	-45 °C to +105 °C
Water vapour diffusion resistance	$\mu = 2,500$
Compression strength	4.3 N/mm² at 23 °C

Pipe outer Ø D		Insulation thickness s [mm]	Max. recommended load axial [N]	Max. recommended load radial [N]	Dimensions [mm]							Part no.	Sales unit	Pack unit
[inch]	[mm]				a	b	b1	B	B1	s1	V			
2½"	76.1	30	2,500	3,600	50	100	90	203	173	4	M10	150707	1	Pieces
3"	88.9		3,000	4,300				211	181			150708		
4"	114.3	40	4,000	6,900	60	120	100	274	238		M12	150709		
	133		4,500	7,700				300	264			167131		
5"	139.7			8,100								150710		
6"	168.3		6,000	9,700				328	288			152055		
8"	219.1	60	9,000	23,000	100	200	140	439	399		M16	159107		
	273		12,000	28,000				493	453			156831		
	323.9		15,000	32,800				544	504			165046		
	355.6		17,000	36,000				576	536			160913		

 Anchor point pipe clamps type 170 FL from DN 400 can be supplied upon request.

PU-Sealer
cartridge à 310 ml

Part no.	Sales unit	Pack unit
122470	1	Pieces

