

MPR-Wall hanger brackets

galvanised

Application

- Ideal as cantilever support structure of multisection pipeways
- Applicable as cantilever bracket for air ducts and cable trays
- Applicable in combination with saddle support and channel support brackets as a cross-beam for pipe attachments in shafts and ducts
- Solid wall bracket for valves and equipment
- For indoor use
- Selected sizes with VdS certificate for the installation of sprinkler systems

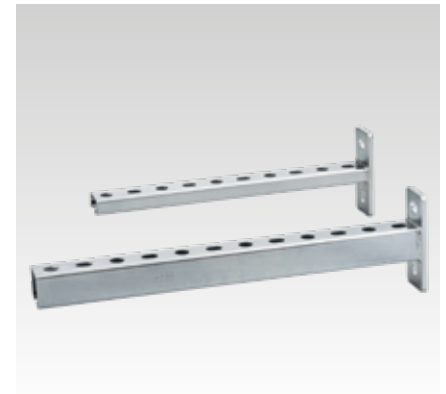
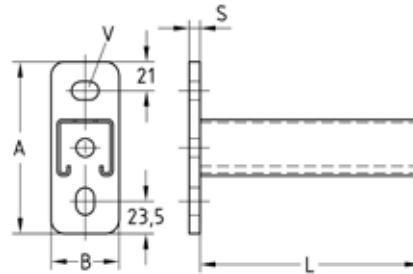

Your advantages

- The strong base plate ensures a high load carrying capacity
- Elongated- and cross-hole for flexible attachment to the building structure
- Variety of lengths covers all construction requirements
- Clean-cut appearance by the use of MPR-protection caps
- Wall hanger brackets with VdS certificate - oblong holes 13 x 34 mm in a 50 mm grid



Wall hanger brackets with VdS certificate

Profile	Length L [mm]	VdS	Fire protection certified	Dimensions [mm]				Part no.	Sales unit	Pack unit
				A	B	s	V			
41/21/2.0	160			125	50	6	13.5 x 20	156763	30	Pieces
	240							156764		
	320							156765	25	
	400							156766		
41/41/2.0	160			165	60	8	13.5 x 20	156767	20	
	240							156768		
	320							156769	15	
	400							156770		
	480							156771	10	
	560							156772		
	640							156773	1	
	720							156774		
	800							156775		
	1,040							156776		
41/41/2.5 BV	150	x	x	165	60	8	13.5 x 20	166150	25	
	300	x	x					166151	20	
	450	x	x					166152	15	
41/62/2.5 BV		x	x	165	60	8	13.5 x 20	166153	1	
	600	x	x					166154		
	800	x	x					166155		
	1,000	x						166156		

MPR-Wall hanger brackets

galvanised

Technical data of brackets:



Features					
Profile	Dimensions H x W x D [mm]	Base plates		MPR-Support channels	
		Material	Admissible steel stress $\sigma_{adm.}$ [N/mm ²]	Material	Admissible steel stress $\sigma_{adm.}$ [N/mm ²]
41/21/2.0	125 x 50 x 6	S235	162	S235	188
41/41/2.0	125 x 50 x 8				
41/41/2.5					
41/62/2.5	165 x 60 x 8	S355MC	231		

Load bearing capacities of brackets for bending around the y-axis:

Profile	Base plate $M_{max.}$ [Nmm]	Length L [mm]	Max. recommended load [N]			
41/21/2.0	112,154	160	1,399	700	700	466
		240	931	466	466	310
		320	696	348	348	232
		400	555	231	278	185
41/41/2.0	275,080	160	3,435	1,718	1,718	1,145
		240	2,287	1,144	1,144	762
		320	1,712	856	856	571
		400	1,367	684	684	456
		480	1,136	568	568	379
		560	971	485	485	324
		640	846	422	423	282
		720	749	373	375	250
		800	671	320	336	224
		1,040	508	185	254	169
41/41/2.5		150	3,664	1,832	1,832	1,227
		300	1,826	913	913	609
		450	1,211	606	606	403
41/62/2.5	542,490		2,397	1,199	1,199	798
		600	1,790	895	895	597
		800	1,332	666	666	444
		1,000	1,054	527	527	351

- For use in areas with requirements on the duration of fire resistance, the boundary conditions set out in the fire test report must be observed.
- The determined loads apply for static loads. Calculation based on Eurocode (EC3).
- The safety coefficient $\gamma = 1.54$ takes into account the partial and combination coefficients as well as the safety factor of the material.
- For the given values, the permissible steel stress and the maximum permissible deflection $L/150$ are not exceeded, taking the deadweight into consideration.
- The load-carrying values refer to the console support. Fastening elements such as plugs and screws, must be chosen in accordance with the loads.