

MPR-VARIO-Saddle support

hot-dip galvanised

Application

- Ideal for variable attachment of MPR-Support channels on slanting steel structures and bulkheads

Your advantages

- Variable angle adjustment possible during installation
- Simple and quick installation due to pre-installed screws and MPR-Threaded plate
- Attachment to the slot of support channels 41/41 possible in all directions
- Positive-fit joining due to interlocking MPR-Support channels and MPR-Threaded plates

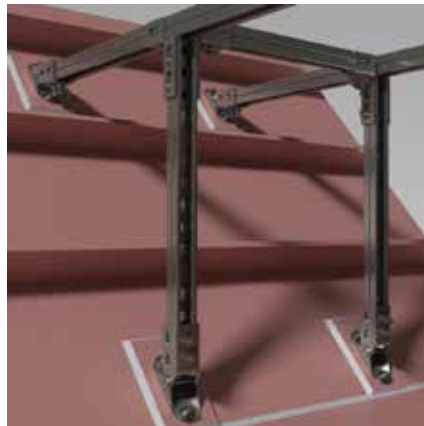

Completely pre-assembled:
 1 MPR-VARIO-Saddle support,
 2 MPR-Threaded plates M10,
 2 Hexagonal head bolts M10,
 2 Washers

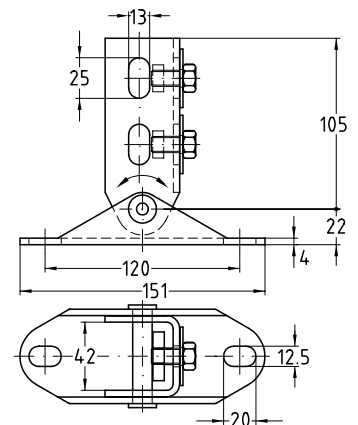

Features



For profiles	Min. angle [°]	Part no.	Sales unit	Pack unit
41/21-41/62	20	160007	1	Pieces

