

MPR-Channel connector type S+

heavy-duty version, hot-dip galvanised

Application

- Fast butt-joining of MPR-Support channels and MPR-Connection lock type S+
- For indoor and outdoor use

Your advantages

- Enables exact alignment of the channels
- Frictional connection via 4 connection locks type S+
- Easy handling thanks to installation with connection lock type S+

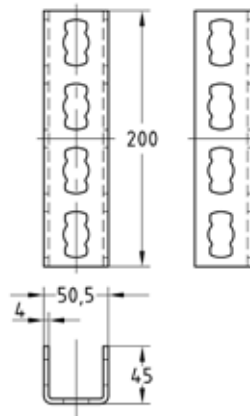

For profiles 41/21-41/124	Part no. 165897	Sales unit 1	Pack unit Pieces
------------------------------	--------------------	-----------------	---------------------

MPR-Diagonal struts type S+

hot-dip galvanised

Application

- Supporting strut for reinforcement of corner joints in structures made of MPR-Support channels and MPR-Connection lock type S+
- Also suitable for lateral support of consoles, e.g. for use with fixed points
- For indoor and outdoor use

Your advantages

- Easily connected with the MPR-Support channels due to installation with the MPR-Connection lock type S+
- Various lengths available for different on-site installation conditions

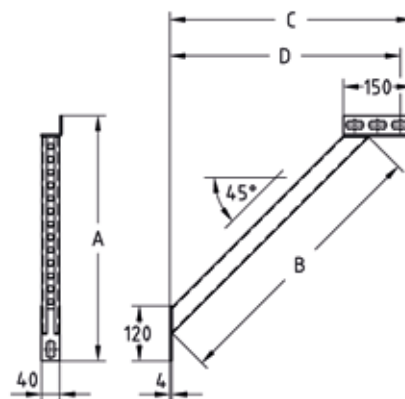

Features

For profiles	Length [mm]	Dimensions [mm]				Part no.	Sales unit	Pack unit
		A	B	C	D			
41/21-41/124	440	395	440	380	355	165866	1	Pieces
	900	741	900	734	709	165868		

