

### MPT-Mounting angles 45°

hot-dip galvanised

#### Application

- Proven mounting angle for corner and angle connections as well as for bracing in combination with MPT-Support profiles Q50, Q80, Q100 and Q150
- Additional connection options due to fourfold perforation

#### Your advantages

- Stable and good value connecting element for connecting MPT-Support profiles
- Any tolerances that may occur can be compensated due to oblong holes in mounting angles

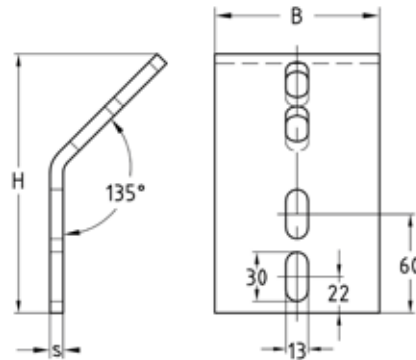

4-hole, for profiles Q50, Q100, Q150

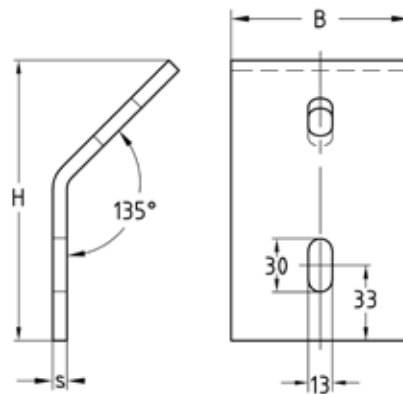

2-hole, for profile Q80

Design	For profiles	Thickness s [mm]	Dimensions [mm]		Weight [kg]	Part no.	Sales unit	Pack unit
			B	H				
4 holes	Q50-2.5, Q100-2.5, Q100-3.5, Q150-2.5	8	100	157.2	1.066	151334	1	Pieces
2 holes	Q80-2.0		80	140	0.83	167933		