

Supporting angle

hot-dip galvanised

Application

- For lateral suspension of pipelines on reinforced concrete beams
- As substructure for the attachment of fittings, e.g. water meters

Your advantages

- Angle element for higher requirements for stability of mounting structures
- Usable as bracket for supporting heavy loads close to a wall
- For supporting cross-beams in confined spaces

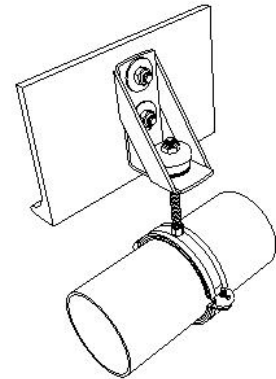
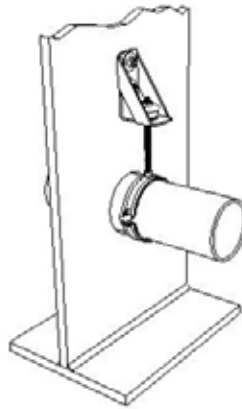
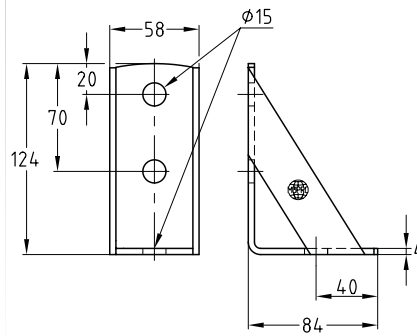

Features



Max. recommended load [N]		5,000	
Design without DÄMMGULAST® Resilient pad	Part no. 127801	Sales unit 25	Pack unit Pieces

