

HP-Clamps

zinc-nickel

Application

- For simple and fast connection of fastening elements and equipment to bulb profiles of the ship's structure without welding

Your advantages

- Using just a single screw connection with little time required for fixing in comparison to the conventional fastenings
- Direct and flexible fastening at any desired position on the bulb profile
- Subsequent fixing also possible after conclusion of the „hot work“
- Slip-resistant fastening to the bulb profile without damaging the corrosion protection due to clamp mechanism
- Light-weight construction to meet the demands in terms of weight reduction in shipbuilding
- High load-bearing capacity of up to 4.5 kN

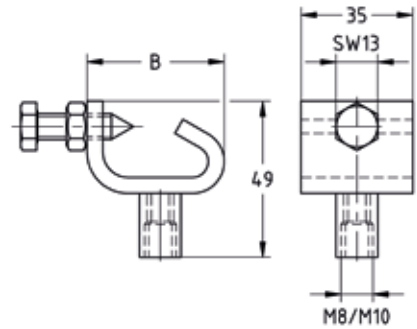

Features



Max. recommended load [N]	Tightening torque [Nm]
4,500	9

For profiles	Connecting thread	Dimensions B [mm]	Part no.	Sales unit	Pack unit
HP 80-120	M8/M10	47	168817	50	Pieces
HP 140-160		56	168818		