

Anchoring cams

Application

- Anchor cams for (one site) welding onto the pipe slides for application as anchor
- Individual applications in combination with all pipe slides

Your advantages

- Two versions available

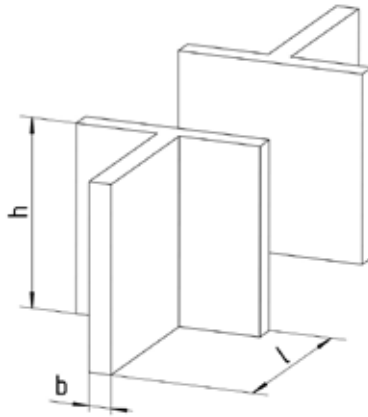

Type N1

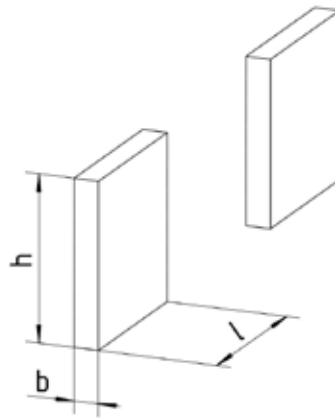

Type N2

Features

Material	Code for material	Surface	Code for surface
S235JR (St37)	W37	untreated	OR
V2A stainless steel	WA2	V2A	OP
V4A stainless steel	WA4	V4A	

Type	Design	Code	Dimensions [mm]			Content [pieces/set]	Weight [kg]	Part no.	Sales unit	Pack unit
			b	h	l					
N1	untreated	W37-OR	6	50	50	2	0.444	1	Set	
	V2A	WA2-OP					0.222			
	V4A	WA4-OP					0.222			
N2	untreated	W37-OR	6	40	40	2	0.15	1	Set	
	V2A	WA2-OP					0.075			
	V4A	WA4-OP					0.075			

 For application of pipe slide type LP-2 as anchor point four anchoring cams are required.