

Cramping elements

hot-dip galvanised

Application

- Applicable in combination with pipe slides as anchor point, guidance with and without lift-off securing

Your advantages

- Simple and efficient attachment of pipes to steel supporting structures, e.g. pipe bridges
- All cramping elements are in cast steel GS 45 with hot-dip galvanised surface
- Available as type K1 and K2

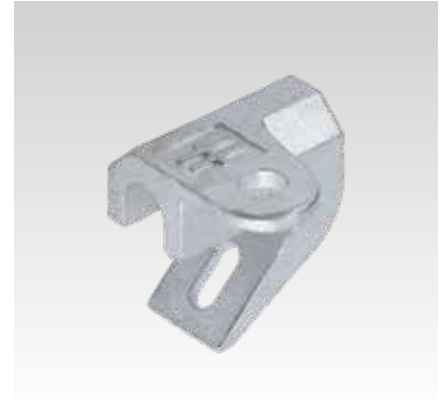
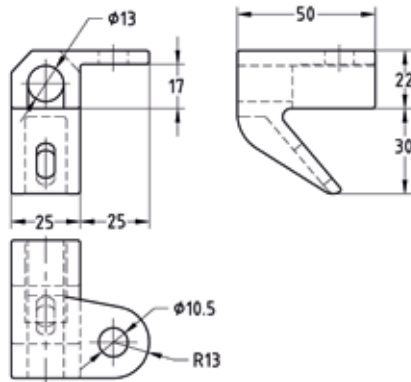

Type K1

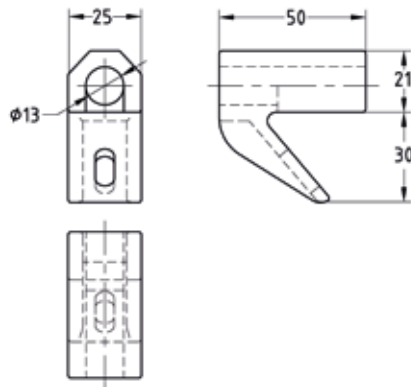

Type K2

Type	Design	Flange thickness min. [mm]	Flange thickness max. [mm]	Thread	Weight [kg]	Part no.	Sales unit	Pack unit
K1	left	6	20	M12	0.23	113238	1	Pieces
	right					113241		
K2	-				0.183	113244		

 Other types available on request.

